

DATE	REV	ECN	APP'D. BY
1/25/06	A5	7452	JM

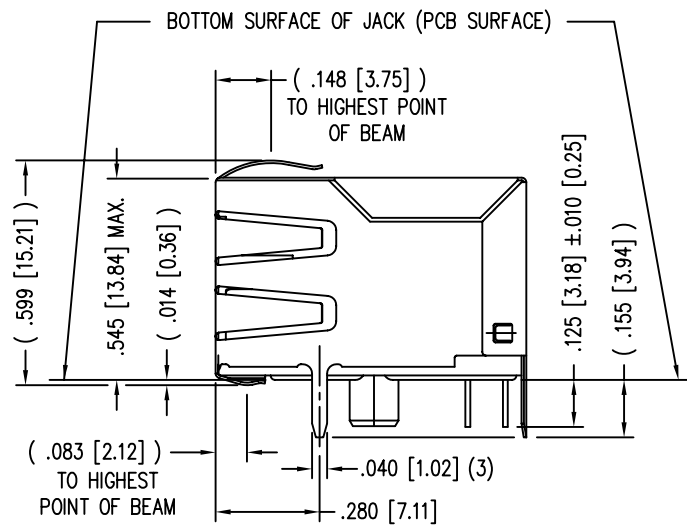
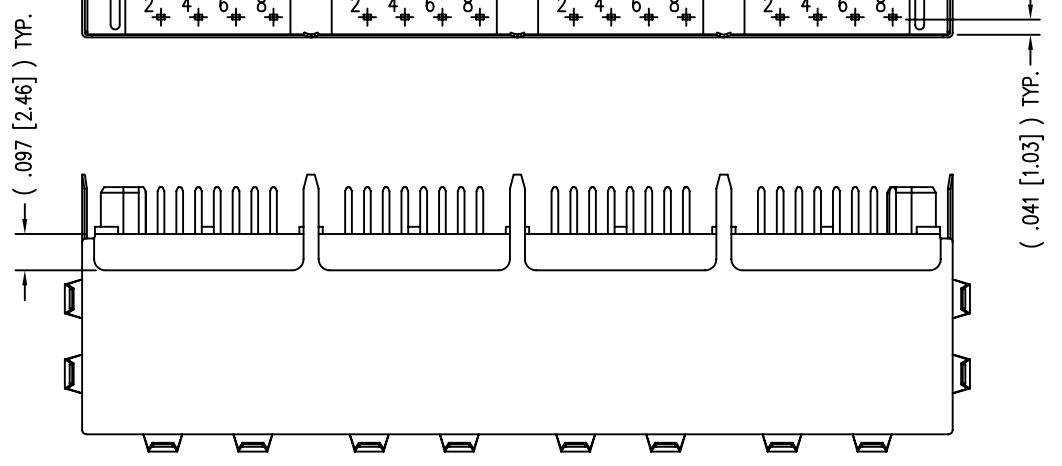
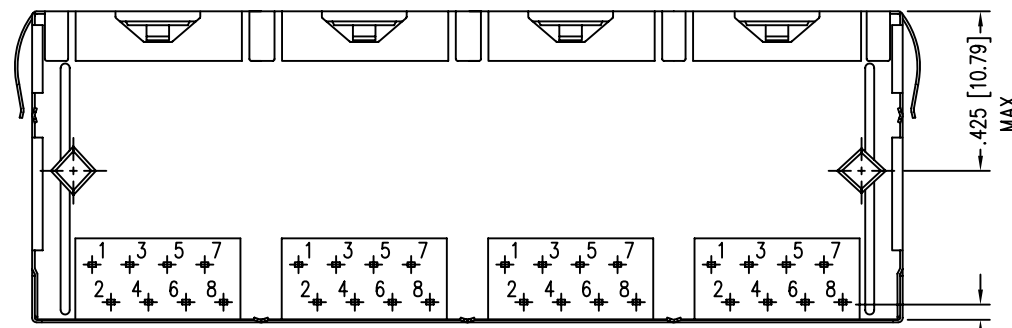
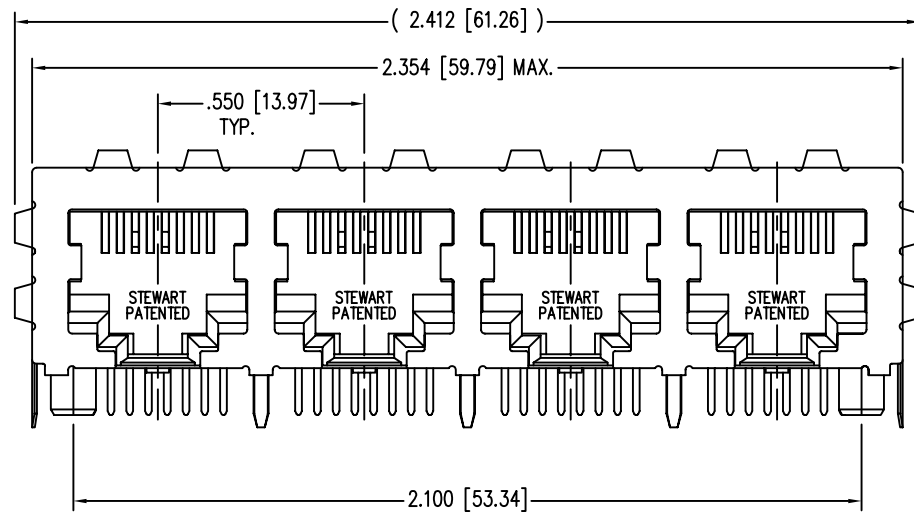
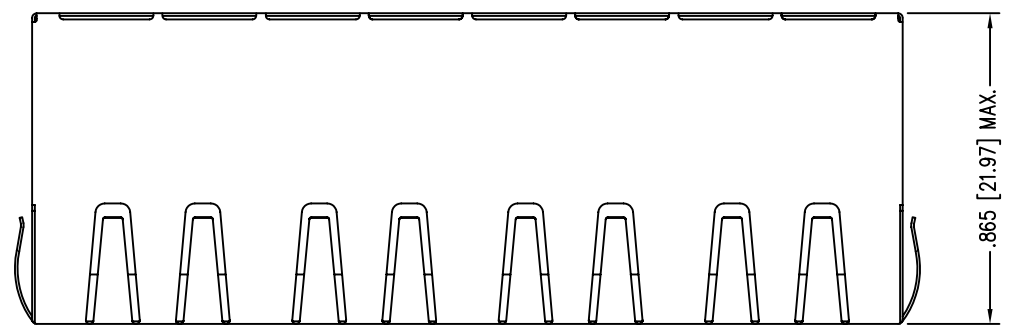

- NOTES:
- CONNECTOR MATERIALS:
HOUSING: THERMOPLASTIC UL94 V-0
CONTACTS/SHIELD: COPPER ALLOY
SHIELD PLATING: NICKEL OR TIN
CONTACT PLATING: SELECTIVE GOLD IN CONTACT AREA
SEE CHART FOR PART NUMBER
 - FOR PRODUCT SPECIFICATIONS SEE PR022-01.
 - TOLERANCES COMPLY WITH F.C.C. DIMENSION REQUIREMENTS.
 - THE SUGGESTED PANEL OPENING IS INTENDED TO GIVE USER THE ABILITY TO HAVE REASONABLE JACK/PANEL CLEARANCES, YET MAINTAIN GROUNDING CAPABILITY. THESE VARIABLES CAN BE ADJUSTED IN EITHER DIRECTION BUT MAY CARRY SOME CONSEQUENCES IN THE FORM OF LOWER MATING FORCES OR TIGHTER ASSEMBLY TOLERANCES.

50 MICRO-INCHES [1.27um]	SS-718804S-A-PG4-AC-50
30 MICRO-INCHES [0.76um]	SS-718804S-A-PG4-AC
CONTACT PLATING IN MATING AREA	PART NUMBER

THIRD ANGLE PROJECTION
DO NOT SCALE DRAWING DRAWING IS SUBJECT TO CHANGE WITHOUT NOTICE
DIMENSIONS: INCHES [METRIC]
UNLESS OTHERWISE SPECIFIED TOLERANCES ARE ±.005 [0.13] ANGLES ARE ± 1°
SHEET NO. 1 OF 2

Bel Stewart Connector

11118 Susquehanna Trail South
Glen Rock, PA 17327-9199
(717) 235-7512 Fax: (717) 235-7954 <http://www.stewartconnector.com>

TITLE: 4 PORT HARMONICA JACK PAC, EMI-RFI ENHANCED SHIELD
ESD GROUNDED

DRN BY: DAB	DATE: 3-24-03
APPD BY: RGC	DATE: 3-24-03
DWG NO. CT710031	REV. A5

THIS DRAWING AND THE SUBJECT MATTER SHOWN THEREON ARE CONFIDENTIAL AND THE PROPRIETARY PROPERTY OF BEL STEWART CONNECTOR AND SHALL NOT BE REPRODUCED, COPIED, OR USED IN ANY MANNER WITHOUT PRIOR WRITTEN CONSENT OF BEL STEWART CONNECTOR. THE SUBJECT MATTER MAY BE PATENTED OR A PATENT MAY BE PENDING.



REV. 6/3/05

B

B

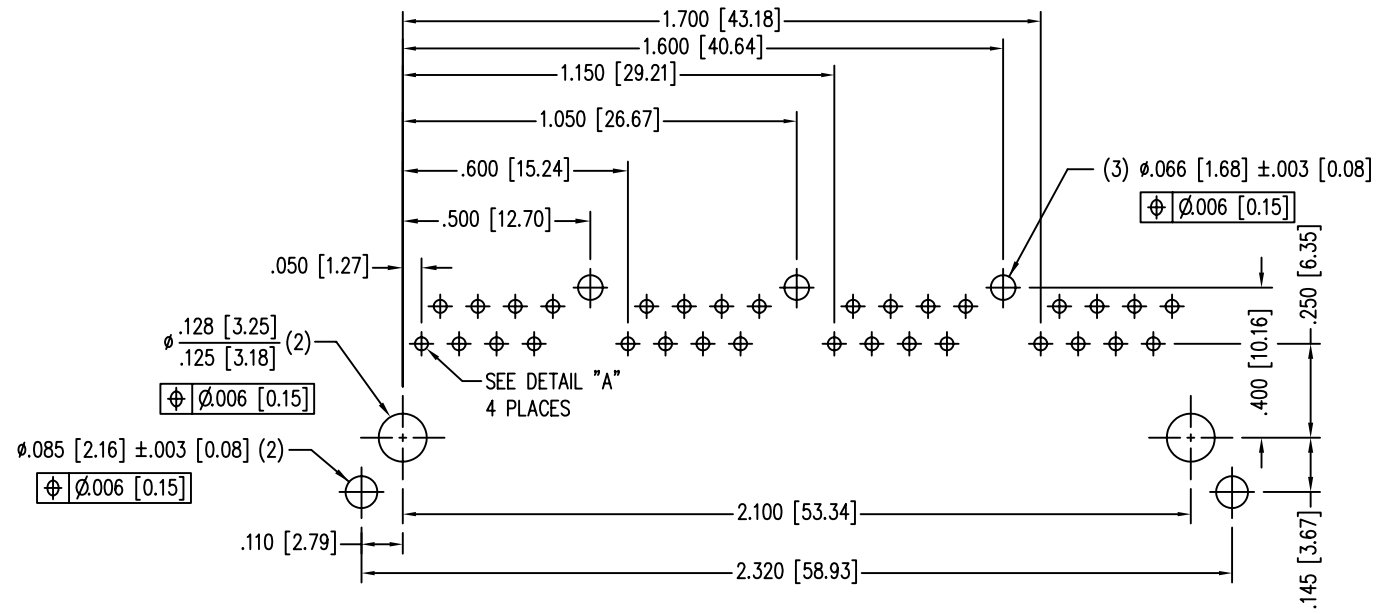

P.C.B. RECOMMENDED HOLE LAYOUT
SEEN FROM COMPONENT SIDE
ALL CENTERLINE DIMENSIONS ARE BASIC.

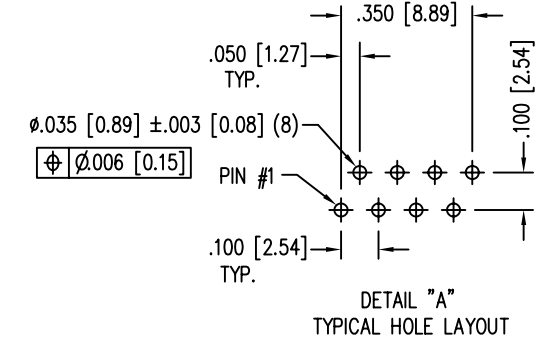

A

A

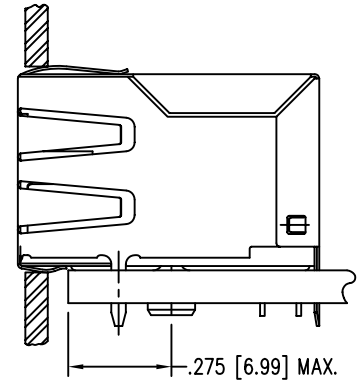
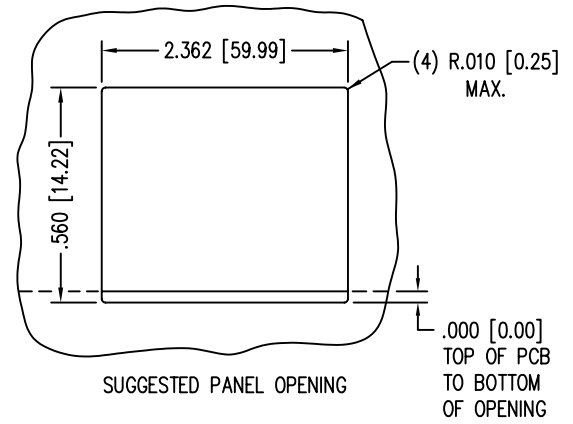

50 MICRO-INCHES [1.27um]	SS-718804S-A-PG4-AC-50
30 MICRO-INCHES [0.76um]	SS-718804S-A-PG4-AC
CONTACT PLATING IN MATING AREA	PART NUMBER

THIRD ANGLE PROJECTION	
DO NOT SCALE DRAWING DRAWING IS SUBJECT TO CHANGE WITHOUT NOTICE	
DIMENSIONS: INCHES [METRIC]	
UNLESS OTHERWISE SPECIFIED TOLERANCES ARE ±.005 [0.13] ANGLES ARE ± 1°	
SHEET NO. 2 OF 2	

Bel Stewart Connector

11118 Susquehanna Trail South
Glen Rock, PA 17327-9199
(717) 235-7512 Fax: (717) 235-7954 <http://www.stewartconnector.com>

TITLE: 4 PORT HARMONICA JACK PAC, EMI-RFI ENHANCED SHIELD
ESD GROUNDED

DRN BY: DAB	DATE: 3-24-03
APPD BY: RGC	DATE: 3-24-03
DWG NO. CT710031	REV. A5

THIS DRAWING AND THE SUBJECT MATTER SHOWN THEREON ARE CONFIDENTIAL AND THE PROPRIETARY PROPERTY OF BEL STEWART CONNECTOR AND SHALL NOT BE REPRODUCED, COPIED, OR USED IN ANY MANNER WITHOUT PRIOR WRITTEN CONSENT OF BEL STEWART CONNECTOR. THE SUBJECT MATTER MAY BE PATENTED OR A PATENT MAY BE PENDING.



REV. 6/3/05